

DRAWING NO	TM521C-A04
PART NAME	Explosive Rendering Console
PART NO	1000357007/A
APPROVE	SHUYI DATE 122714

SAP NO.	Model Name
MTM0517-00	T-7xi-C(1US)
MTM0518-00	T-7xi-C(2KM)
MTM0522-00	T-7xi-C(4JP)
MTM0519-00	T-7xiIRF-C(1US)
MTM0520-00	T-7xiIRF-C(2KM)
MTM0523-00	T-7xiIRF-C(4JP)

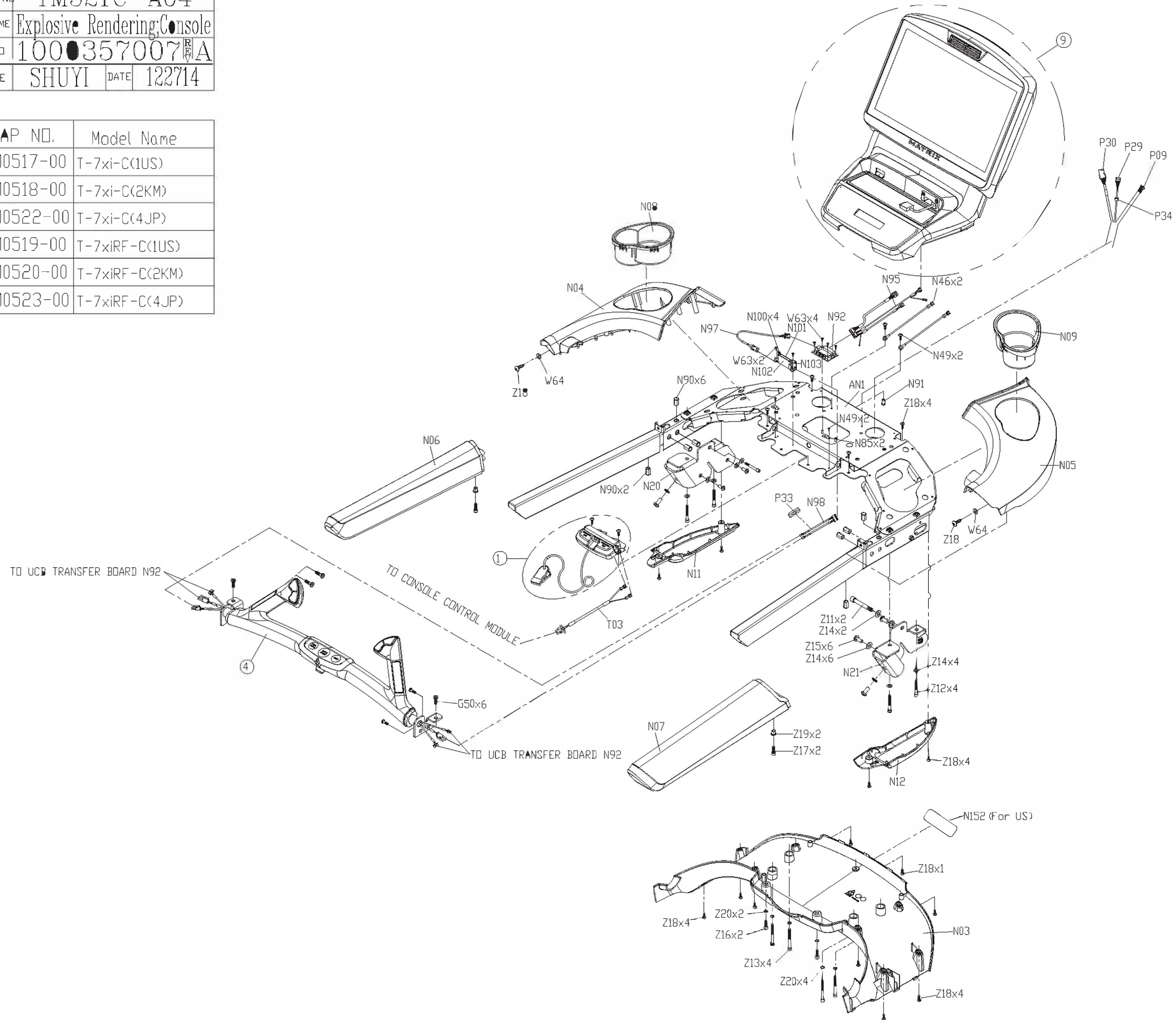

DRAWING NO	TM521D-AN6		
PART NAME	Console Set		
PART NO	1000357031 REV B		
APPROVE	SHUYI	DATE	030615

Part NO	Description

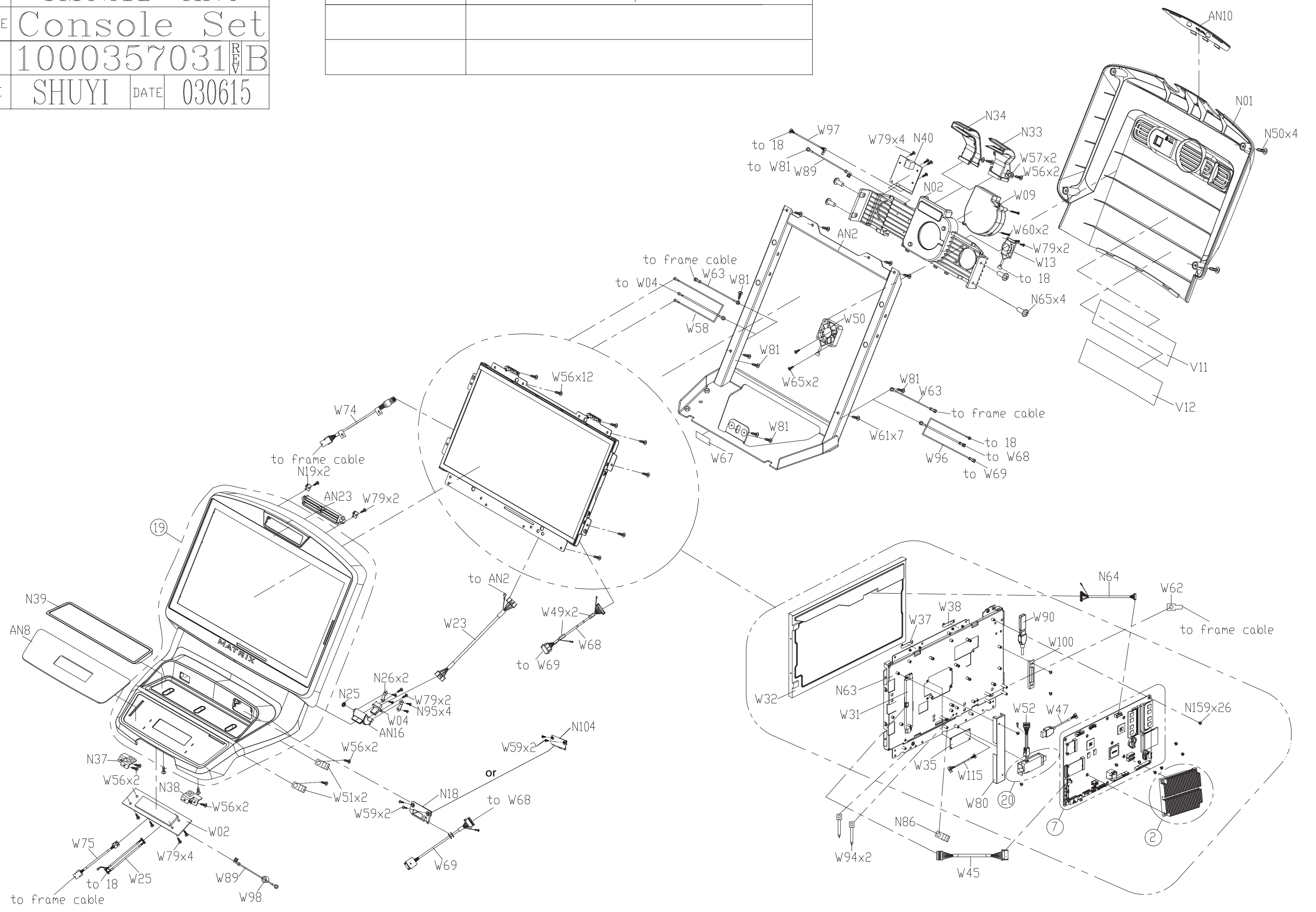

DRAWING NO	TM521-AN10
PART NAME	Touch Panel Set
PART NO	1000228807 C
APPROVE	Hsinyen
DATE	050213

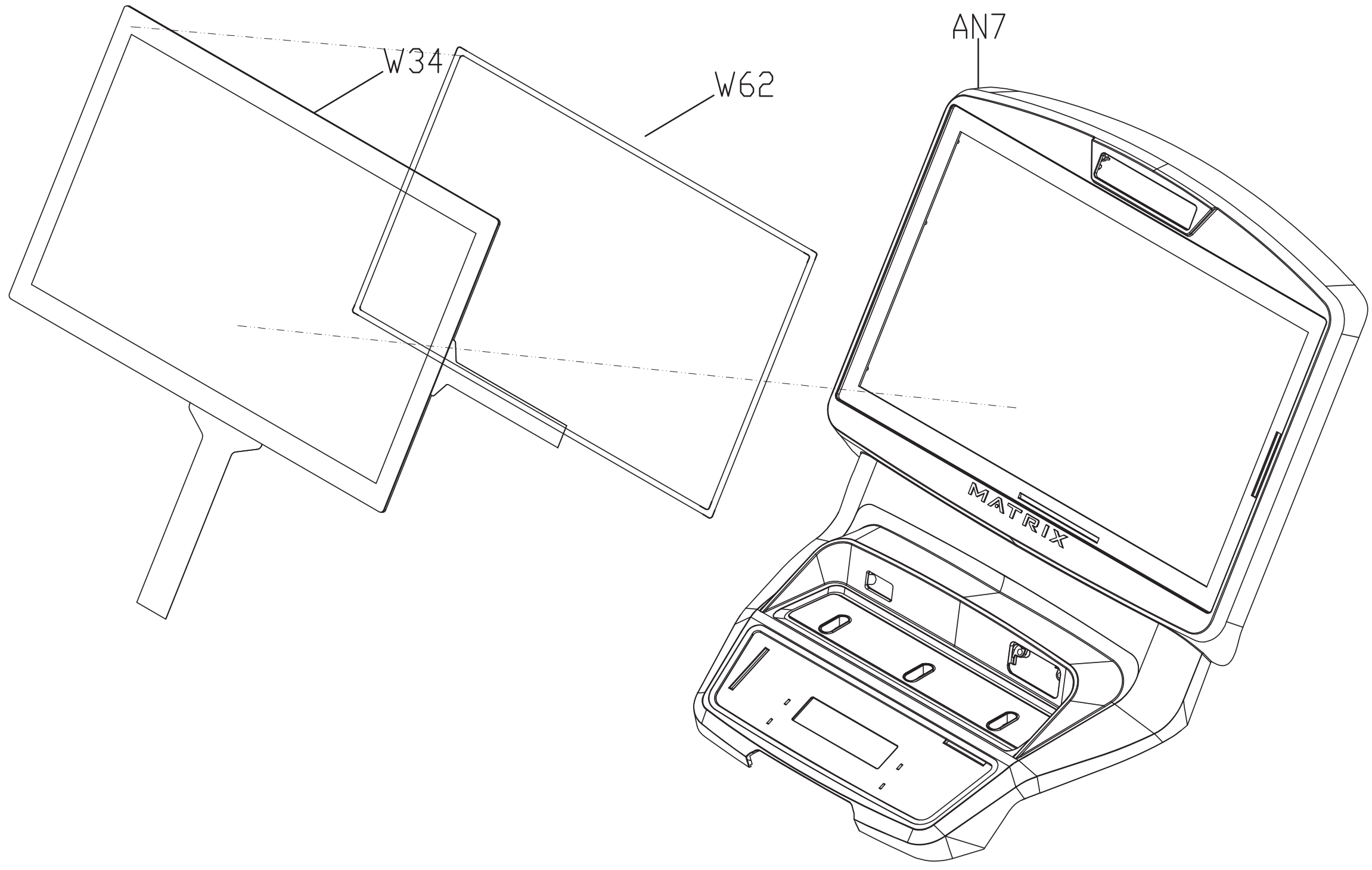

DRAWING NO	TM520-AG21		
PART NAME	Handlebar Set		
PART NO	As Attachment REF		
APPROVE	SHUYI	DATE	012115

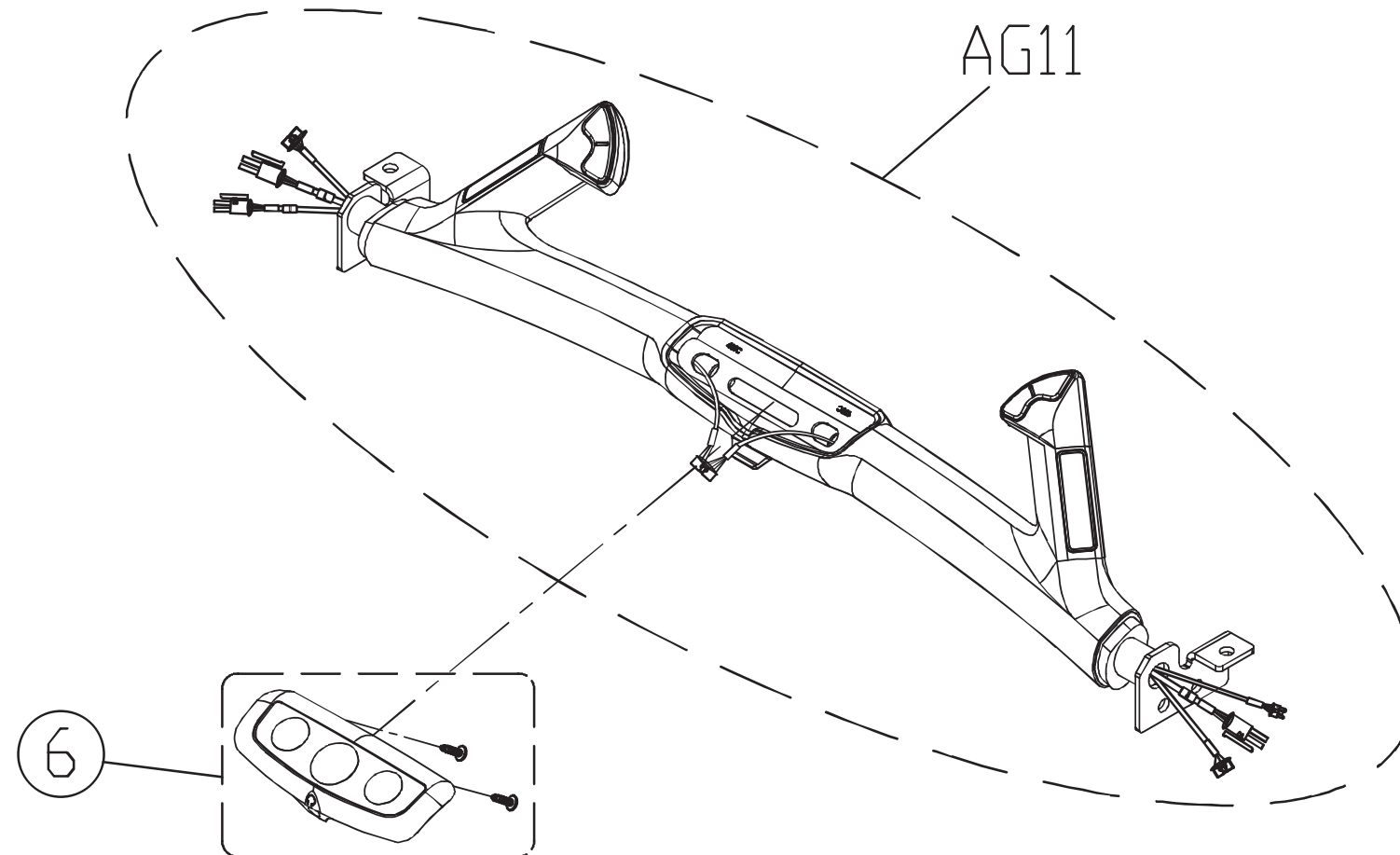

Part NO	Description
1000228703	Handlebar Set;English
1000303220	Handlebar Set;Japan
1000319947	Handlebar Set;Brazil
1000350145	Handlebar Set;German
1000350148	Handlebar Set;Spanish
1000350153	Handlebar Set;Italian
1000350157	Handlebar Set;French
1000350160	Handlebar Set;Dutch
1000350167	Handlebar Set;Polish
1000350163	Handlebar Set;Portuguese

DRAWING NO	TM520-AG12		
PART NAME	Quick Start Overlay Set		
PART NO	As Attachment ^{R/E}		
APPROVE	SHUYI	DATE	071514

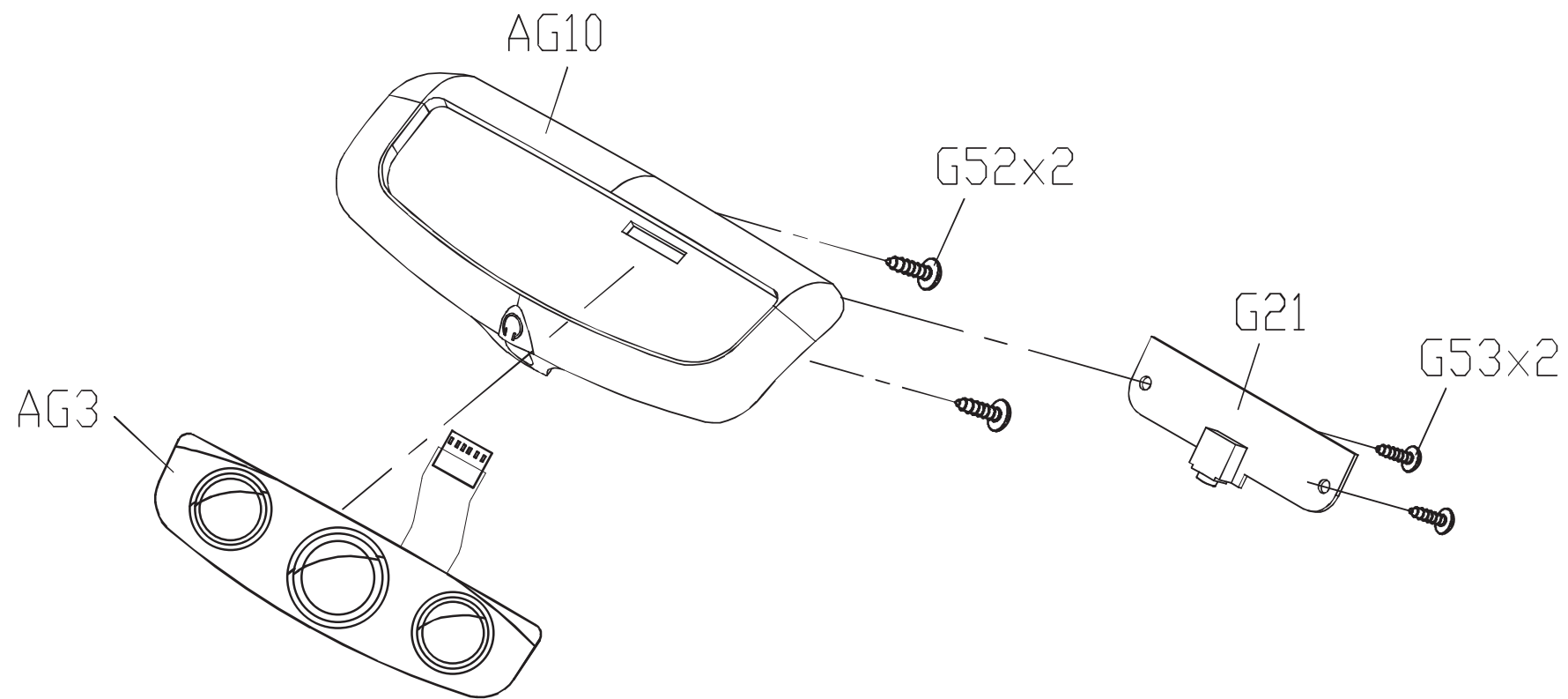

Part NO	Description
1000228679	ES/MS;English;T-7xe-04-C
1000303221	ES/MS;Japan;T-7xe-04-C
1000319948	MS;Portuguese;T-7xe-04-C
1000350146	MS;German;T-7xe-04-C
1000350150	MS;Spanish;T-7xe-04-C
1000350155	MS;Italian;T-7xe-04-C
1000350158	MS;French;T-7xe-04-C
1000350161	MS;Dutch;T-7xe-04-C
1000350168	MS;Polish;T-7xe-04-C

DRAWING NO	TM501-AT6		
PART NAME	SAFETY KEY SET		
PART NO	1000233602 ^R _B		
APPROVE	S.T.C	DATE	083112

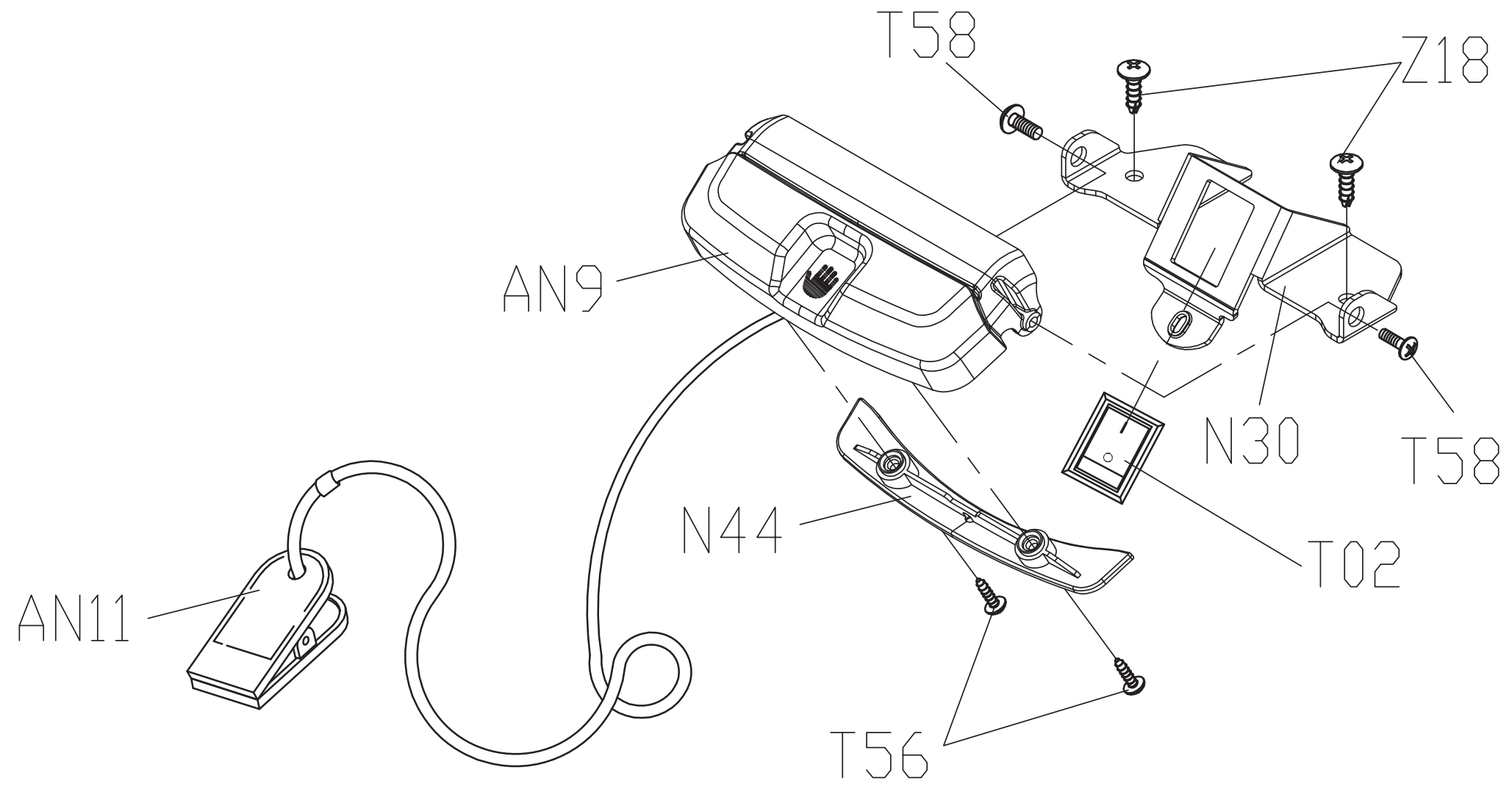

DRAWING NO	TM502-AG11		
PART NAME	Handlebar Set		
PART NO	1000207642 ^R _B		
APPROVE	SHUYI	DATE	030111

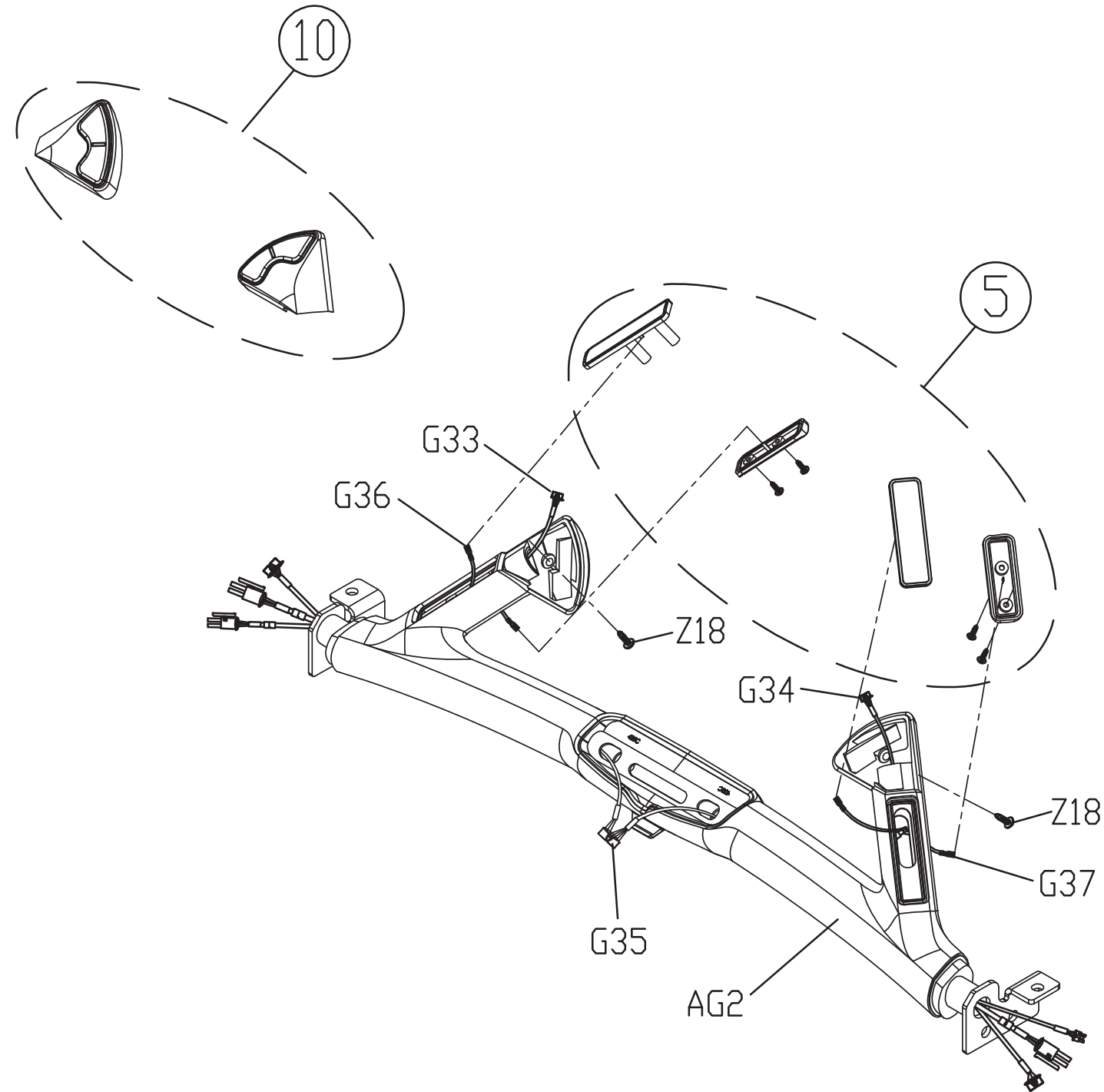

DRAWING NO	TM502-AG12		
PART NAME	Quick Key Set		
PART NO	0000089687 ^R ₁ B		
APPROVE	SHUYI	DATE	101211

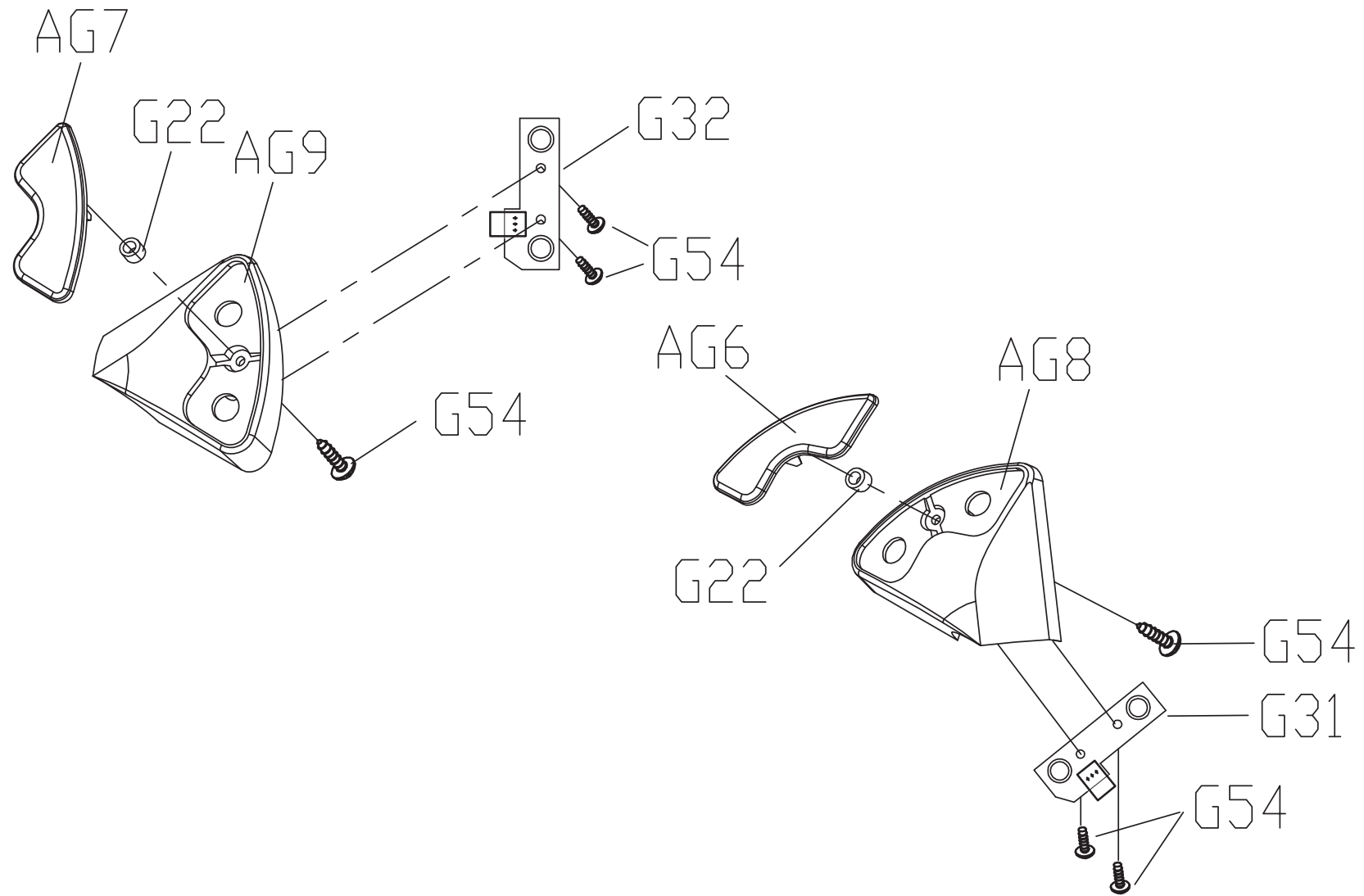

DRAWING NO	TM501-AT13		
PART NAME	Safety Switch Set		
PART NO	1000352475 ^R _B		
APPROVE	JARVIS	DATE	100314

Note: Length of assembly(Chip/Key ring)860~870mm

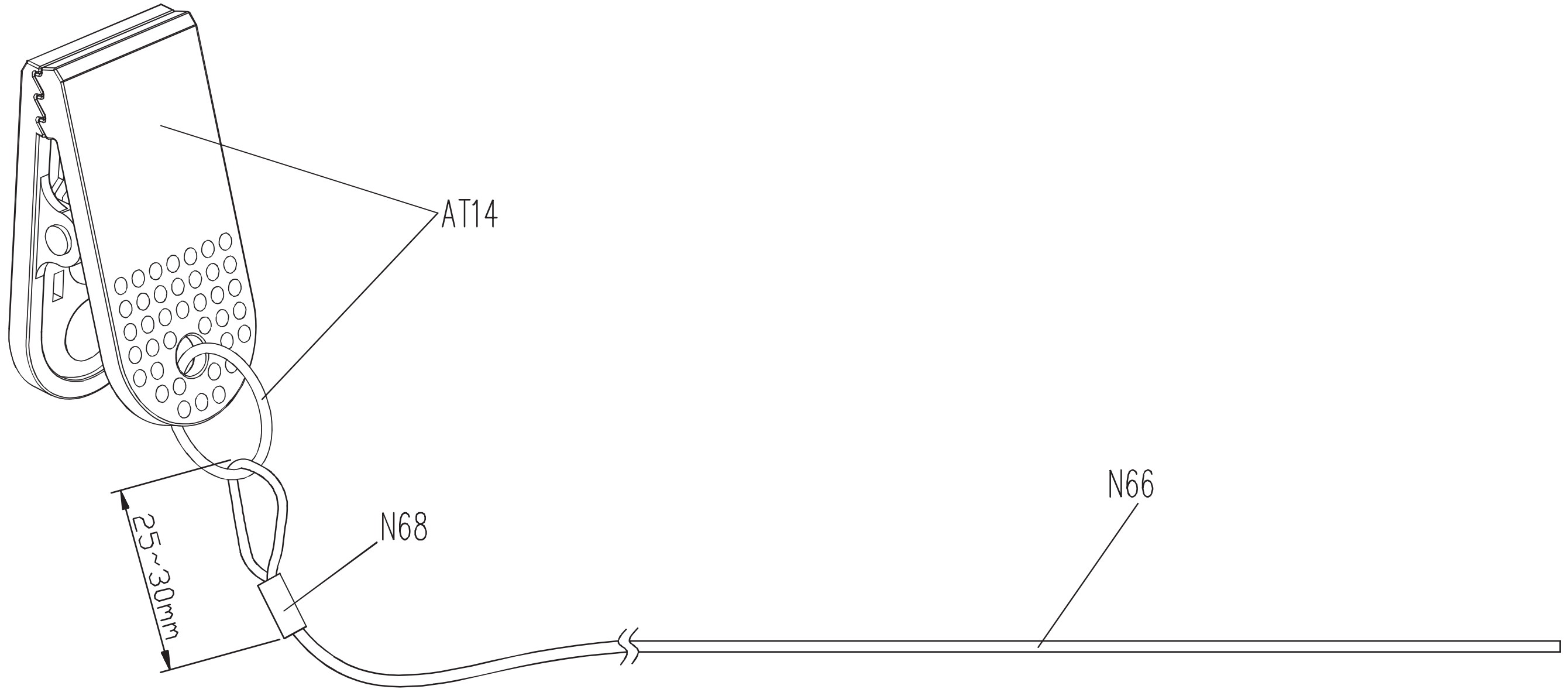

DRAWING NO	TM501-AT14		
PART NAME	Safety Switch Clip Set		
PART NO	1000352479 ^R _B		
APPROVE	JARVIS	DATE	100314

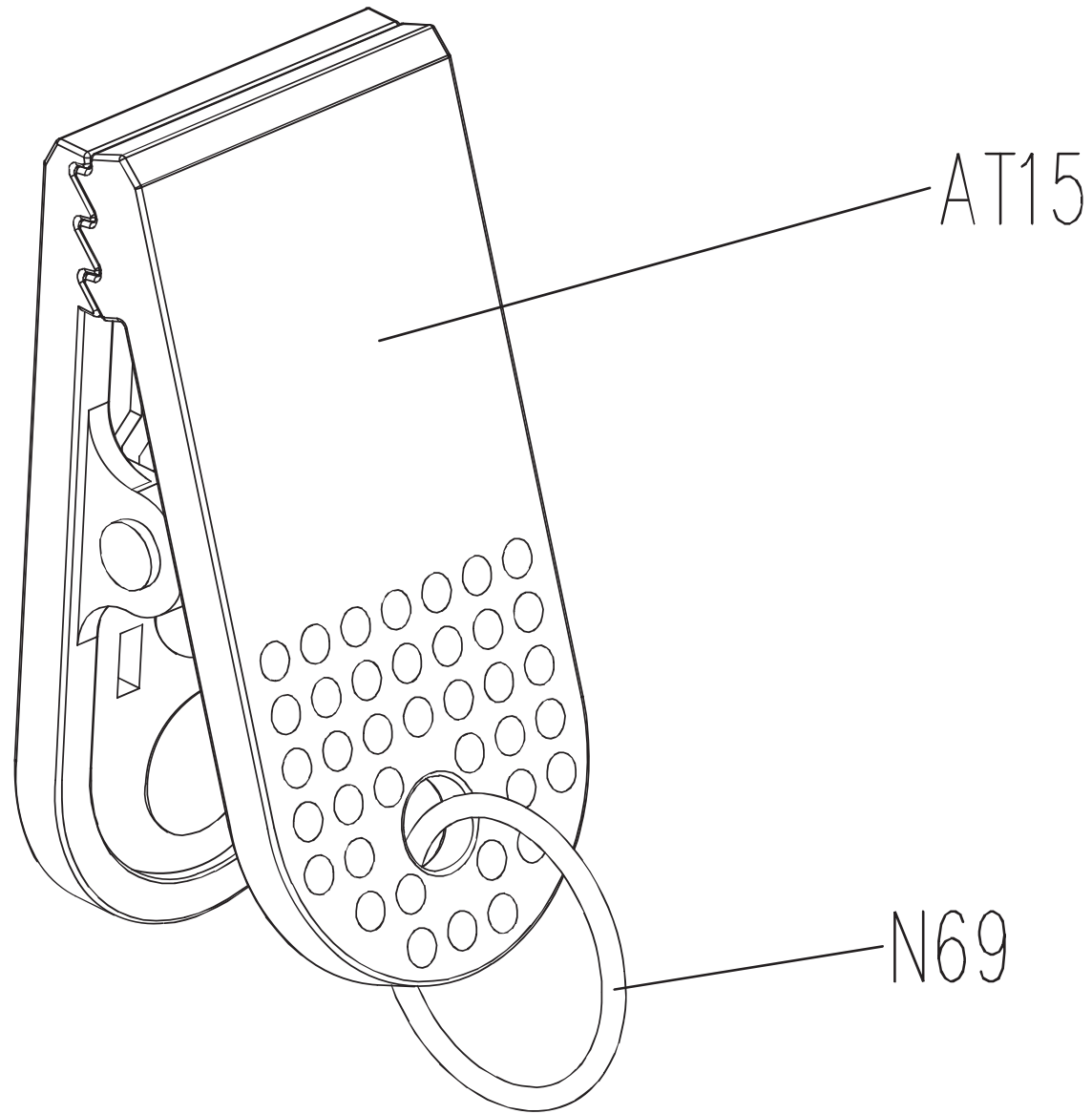

DRAWING NO	EP614C-AW51		
PART NAME	TV STICK SET		
PART NO	1000356574 ^R / ₁ A		
APPROVE	Hsinyen	DATE	122314

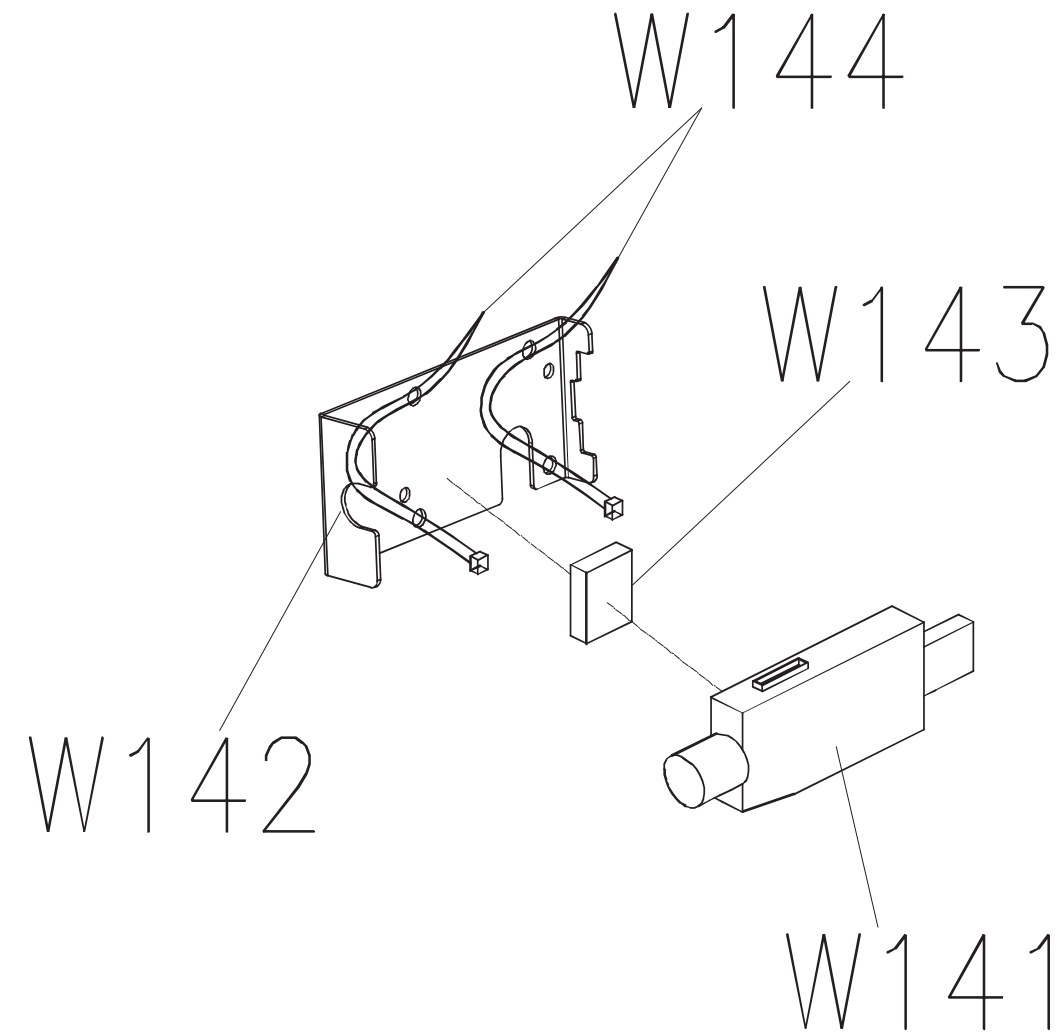

DRAWING NO	TM521-W116		
PART NAME	Heat Sink Set		
PART NO	1000332751B		
APPROVE	Hsinyen	DATE	090413

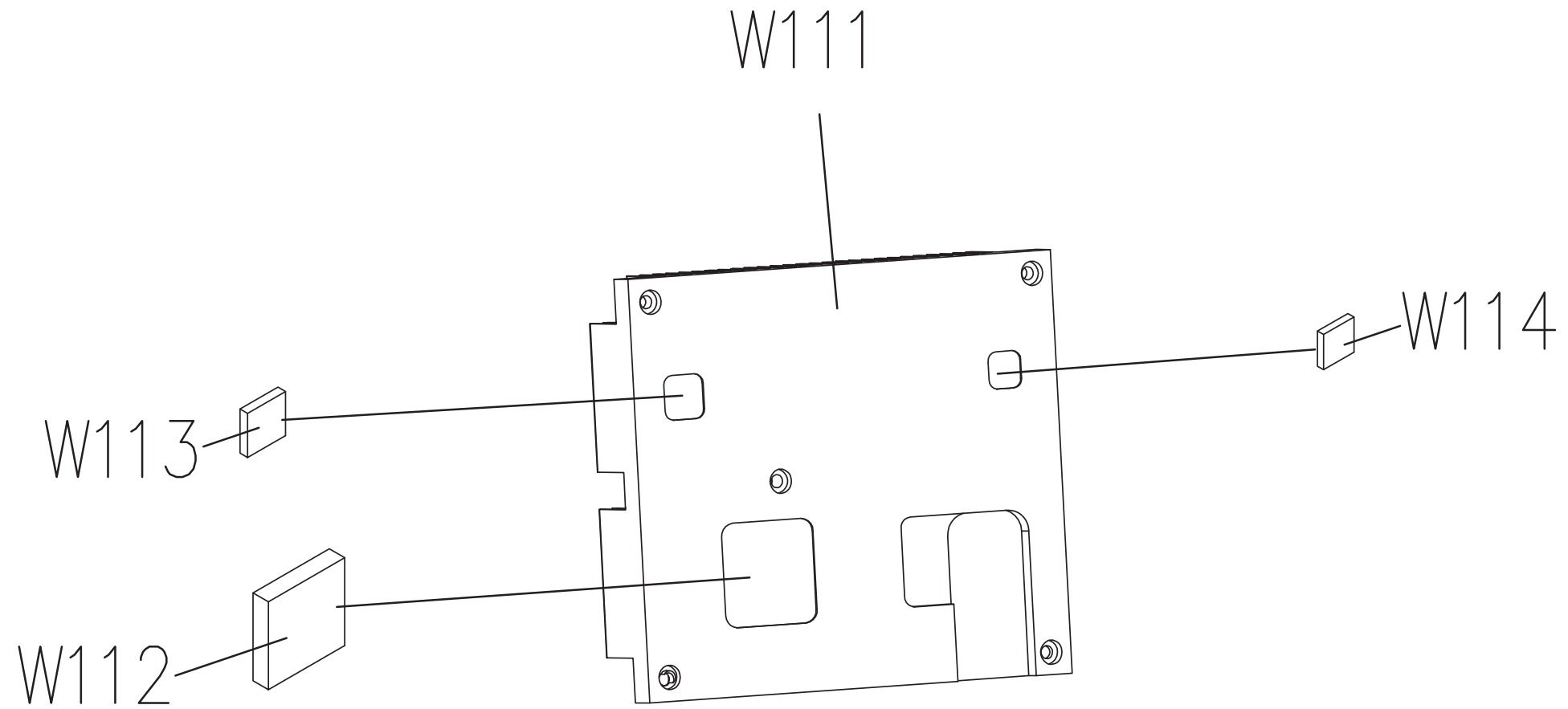

DRAWING NO	EP614-AW11		
PART NAME	Control Board Set		
PART NO	1000228656 R/J		
APPROVE	Sunny	DATE	060614

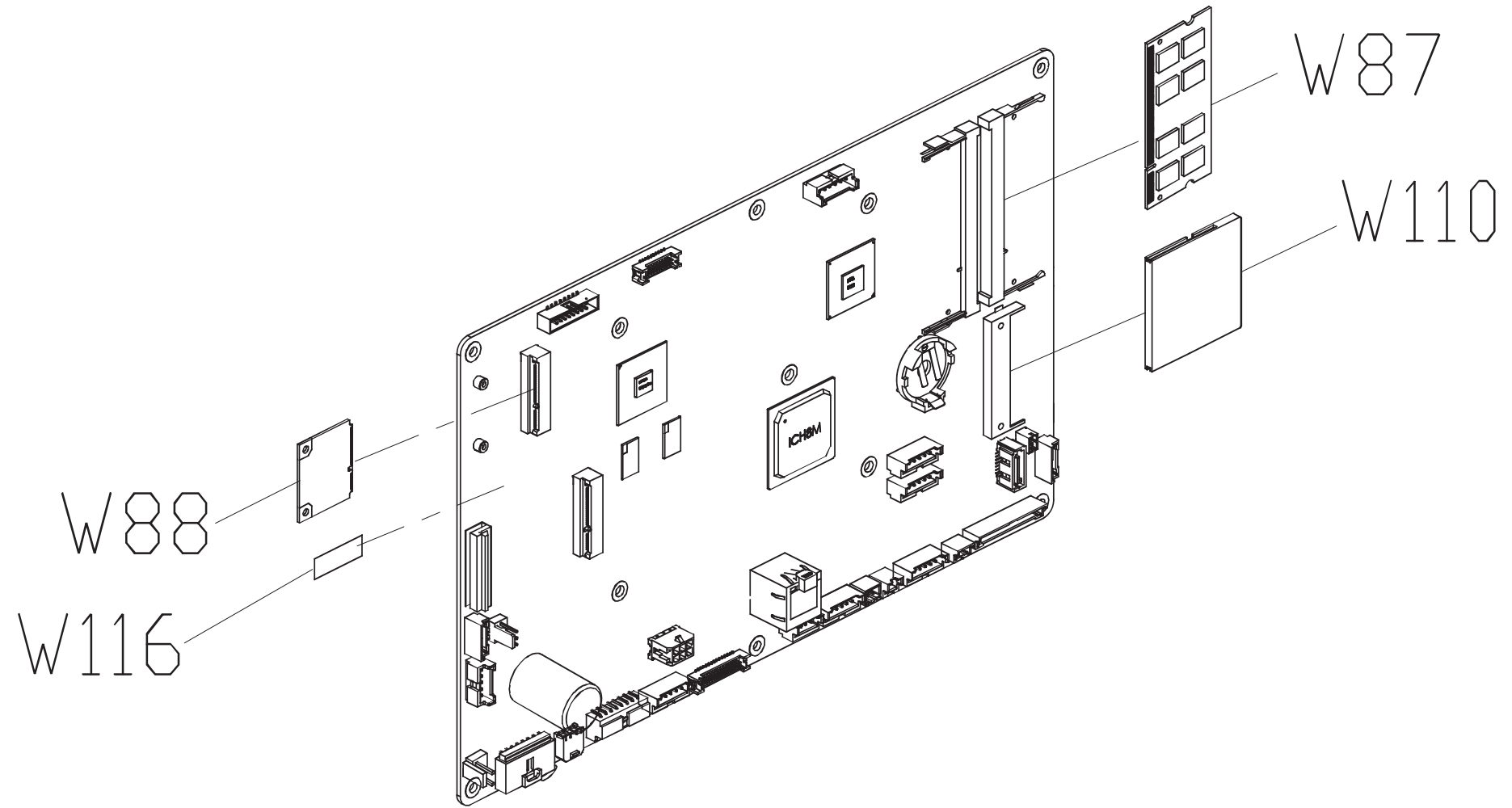



T7x-01-C

0000091816

HR GRIP COVER SET

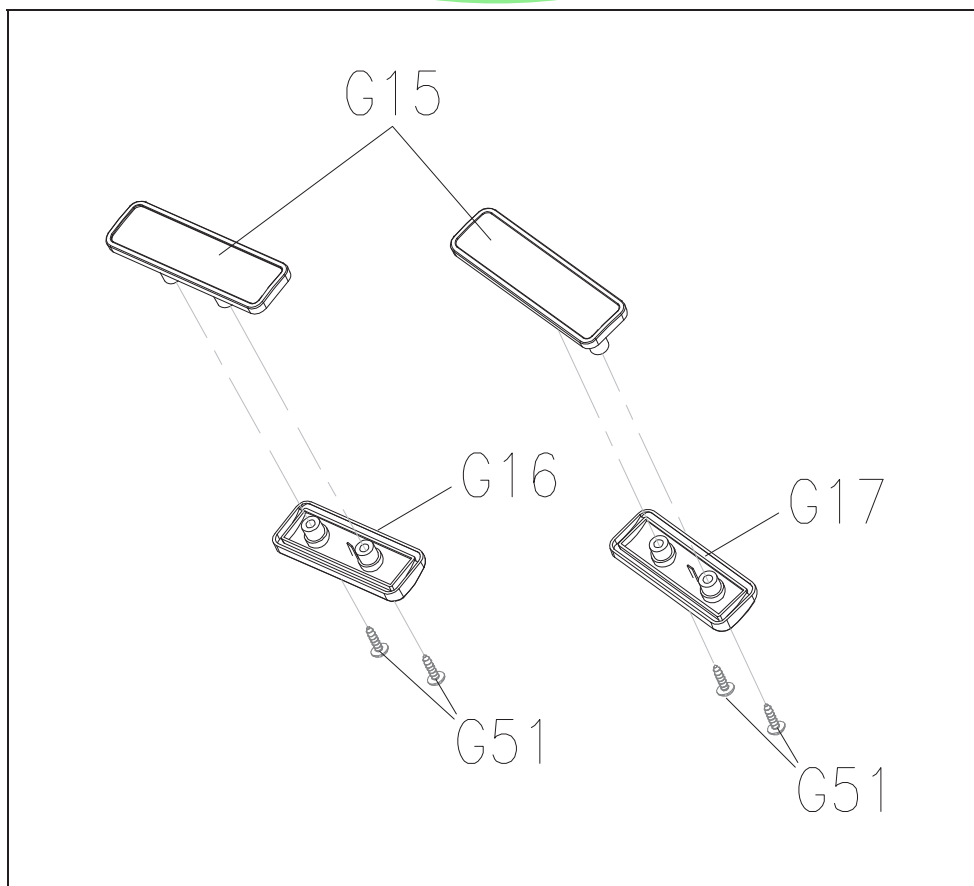

Item No.	SAP Part NO	Description	QTY
G15	0000086068	COVER ; SENSOR ; UPPER	2
G16	0000086092	COVER ; SENSOR ; LEFT ;	1
G17	0000086271	COVER ; SENSOR ; RIGHT ;	1
G51	0000087858	SCREW ; PHILLIP ; ROUND ;	4